



# MT4400

ANTENNA MOUNT TRAVELING WAVE TUBE  
MEDIUM POWER AMPLIFIER

FOR SATELLITE UPLINK APPLICATIONS



C-BAND: 750W  
Ku-BAND: 750W  
DBS-BAND: 500W, 750W  
OTHER AVAILABLE FREQUENCIES  
TRI-BAND  
DUAL-BAND  
X-BAND

## AVAILABLE SYSTEM OPTIONS:

MT4411 1 + 1 Redundant System

MT4412 1 + 2 Redundant System

MT44PC Phase Combined, Single Path  
Redundant System

MT44PC2 Phase Combined, Dual Path  
Redundant System

Other Configurations Available Upon Request

## AVAILABLE AMPLIFIER OPTIONS:

Block Upconverter (Int./Ext. 10 MHz Reference)

Ethernet

Linearizer

Switchover Control

Mounting Configurations

Extended Band Operations

Remote Controller

Hand-Held Local Controller

+60°C Ambient Operation

## FEATURES:

**Weather-Resistant Antenna Mount TWT Amplifier**

**Phase Noise 10 dB Below IESS-308**

**Extensive Built-In Diagnostic Capabilities**

**Advanced Thermal Design**

**Optional Integrated Block Upconverter**

**Rugged Construction For Extreme Environments**

**Optional Hand-Held Controller For Total  
Local Monitoring And Control**

**Prime Power Interfaces To A Wide Variety Of  
Voltages And Frequencies**

**Downloadable Maintenance And Event Logs From  
Diagnostic Port**

**Field Replaceable Modules For Unsurpassed  
Serviceability**

ISO 9001



501 S. Woodcreek Drive, Bolingbrook, IL U.S.A., 60440-4999 • 630-759-9500 FAX: 630-759-5018

# MT4400

## TRAVELING WAVE TUBE MEDIUM POWER AMPLIFIER

ELECTRICAL SPECIFICATIONS	C-BAND		X-BAND	Ku-BAND	DBS-BAND	
	750 W		750 W	750 W	500 W	750 W
Frequency Range (F <sub>0</sub> ) (Standard): (Extended): (Extended): (Extended):	5.850 - 6.725 GHz Option: 5.850 - 7.100 GHz Option: 5.850 - 6.750 GHz Option: 5.850 - 6.450 GHz		7.90- 8.40 GHz	13.75 - 14.50 GHz Option: 12.75 - 14.50 GHz	17.3 - 18.4 GHz	
Output Power (min.): Tube Output Flange: HPA Output Flange:	750 W (58.75 dBm) 665 W (58.25 dBm)		750 W (58.75 dBm) 665 W (58.25 dBm)	750 W (58.75 dBm) 665 W (58.25 dBm)	500 W (57 dBm) 420 W (56.23 dBm)	750 W (58.75 dBm) 665 W (58.25 dBm)
Gain: At Rated Power (min.): Small Signal Gain (SSG) (min.): Attenuation Range: Maximum SSG Variation Over: Narrow Band: Per 500 MHz: Slope, Max.: Gain Stability: Stability, Any Freq. Over Entire Temp.: Stability, Any Freq. ±10°C:	72 dB 77 dB 30 dB (0.10 Step) .5 dB/40 MHz 2.5 dB ±0.04 dB/MHz		71 dB 76 dB 30 dB (0.10 Step) 1.0 dB/80 MHz 2.5 dB ±0.04 dB/MHz	72 dB 77 dB 30 dB (0.10 Step) 1.0 dB/80 MHz 2.5 dB ±.04 dB/MHz	65 dB 71 dB 30 dB (0.10 Step) 1.0 dB/80 MHz 4.0 dB ±.04 dB/MHz	
Input VSWR:	1.20:1 max. with respect to 50 ohms				1.25:1	
Output VSWR:	1.25:1 max.				1.3:1	
Load VSWR:	2.0:1 max. without damage, continuous					
AM/PM Conversion: At Rated Power: 6 dB Below Rated Power:	6.0°/dB max. 2.5°/dB max.		6.0°/dB max. 2.5°/dB max.	6.0°/dB max. 2.5°/dB max.	8.0°/dB max. 3.0°/dB max.	
Residual AM Noise, Max.: To 10 kHz: 10 - 500 kHz: Above 500 kHz:	-50 dBc -20 (1.5 + Log <sub>f</sub> kHz) dBc -85 dBc					
Harmonic Output, Max.:	-60 dBc					
Noise & Spurious, Max.: Receive Band (Standard): (Extended): Transmit Band (F <sub>0</sub> ):	-150 dBW/4 kHz, 3.4 - 4.2 GHz -150 dBW/4 kHz, 3.4 - 4.2 GHz -70 dBW/4 kHz		-70 dBW/4 kHz, 7.23 - 7.75 GHz N/A -70 dBW/4 kHz	-150 dBW/4 kHz, 10.7 - 12.75 GHz -150 dBW/4 kHz, 10.7 - 11.7 GHz -70 dBW/4 kHz	-150 dBW/4 kHz, 10.7 - 12.75 GHz N/A -65 dBW/4 kHz	
Phase Noise, Max.: AC Fundamental: Sum Of All Except AC Fundamental:	10 dB below IESS Phase Noise Profile -50 dBc -47 dBc					
Intermodulation (for 2 equal carriers relative to single carrier rated output): Linearizer Option:	Total P <sub>0</sub> -4 dB -7 dB		IM Product max. -18 dBc -24 dBc	Total P <sub>0</sub> -4 dB -7 dB		IM Product max. -17 dBc -23 dBc
Group Delay, Max.: Linear: Parabolic: Ripple:	Any 40 MHz Bandwidth 0.01 ns/MHz 0.005 ns/MHz <sup>2</sup> 0.5 ns p-p		Any 40 MHz Bandwidth 0.01 ns/MHz 0.005 ns/MHz <sup>2</sup> 0.5 ns p-p	Any 80 MHz Bandwidth 0.01 ns/MHz 0.005 ns/MHz <sup>2</sup> 0.5 ns p-p	Any 80 MHz Bandwidth 0.01 ns/MHz 0.005 ns/MHz <sup>2</sup> 0.5 ns p-p	
Prime Power: Voltage: Power Consumption:  Power Factor: In-Rush: Input Transients:	180 - 264 VAC, 1-phase, 47 - 63 Hz 2.4 KVA typ. at rated power out/1.65 KVA typ. at rated power -10 dB (input power will increase if the HPA is driven to saturation) 0.95 min. 28A max. EN61000-4-4,4-5,4-11 (Surge, Fast Transients, Line Dropout)					

Note: Performance information is subject to change without notification. Contact MCL for the latest specifications (TN4400-1).

## RF BLOCK DIAGRAM

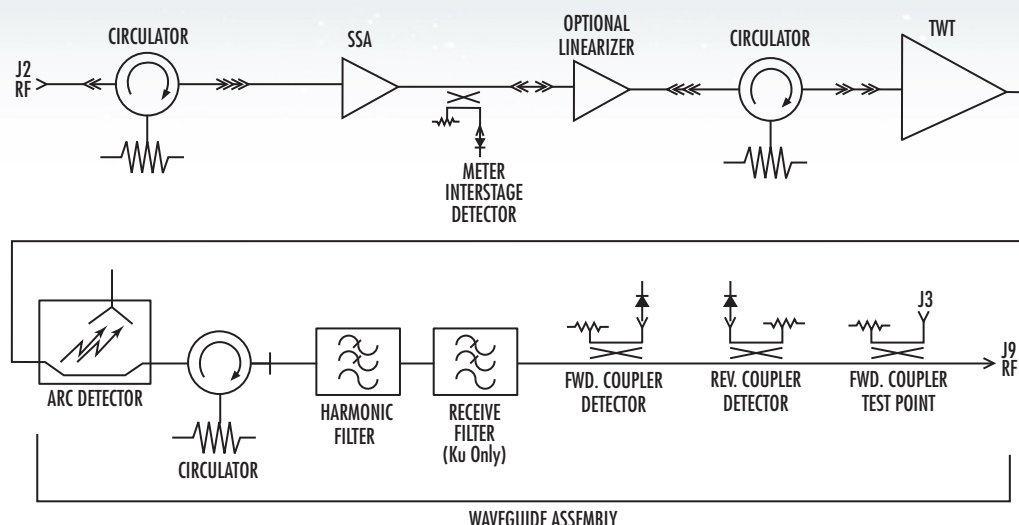

## CONTROL AND STATUS CAPABILITIES

TYPE	FUNCTION		
Controls	Filament ON/OFF Transmit/Standby RF ON/OFF Reset Attenuation	Units Select Hold Power ON/OFF Auto Switching (1:1) Manual Switching (1:1)	Fault Counter ON/OFF Antenna Position (1:1) Load Position (1:1) Local Remote Computer
Adjustable Parameters	Auto Power Tube Temperature Alarm RF Low Alarm Comm Address Date	Tube Overdrive Alarm RF Reflected Power Alarm RF High Alarm Comm Band Rate Time	Tube Overdrive Fault RF Reflected Power Fault Filament Under Current Fault Comm Protocol
Meters	RF Forward Power Helix Voltage Filament Delay	Tube Drive Helix Current Tube Temperature	RF Reflected Power Filament Current PS Temperature
Faults	Tube Temperature Switch Tube Temperature Analog Helix Run Current HV Under Volt	WG Pressure Helix Surge Current HV Over Volt User Interlock	Arc Test Failed PS Temperature Chassis Interlock Filament Under Current
Alarms	RF High RF Reflected Blower Failed Exciter	RF Low Tube Temperature AC Low Line	Tube Overdrive PS Temperature RF Switch Failed
Additional Status	Delay Summary Alarm Maintenance Log	Transmit Selected Summary Fault Event Log	Sampler Port Cal Table RF Low Switching ON/Off Fault Log

# MT4400

## OUTLINE DRAWING

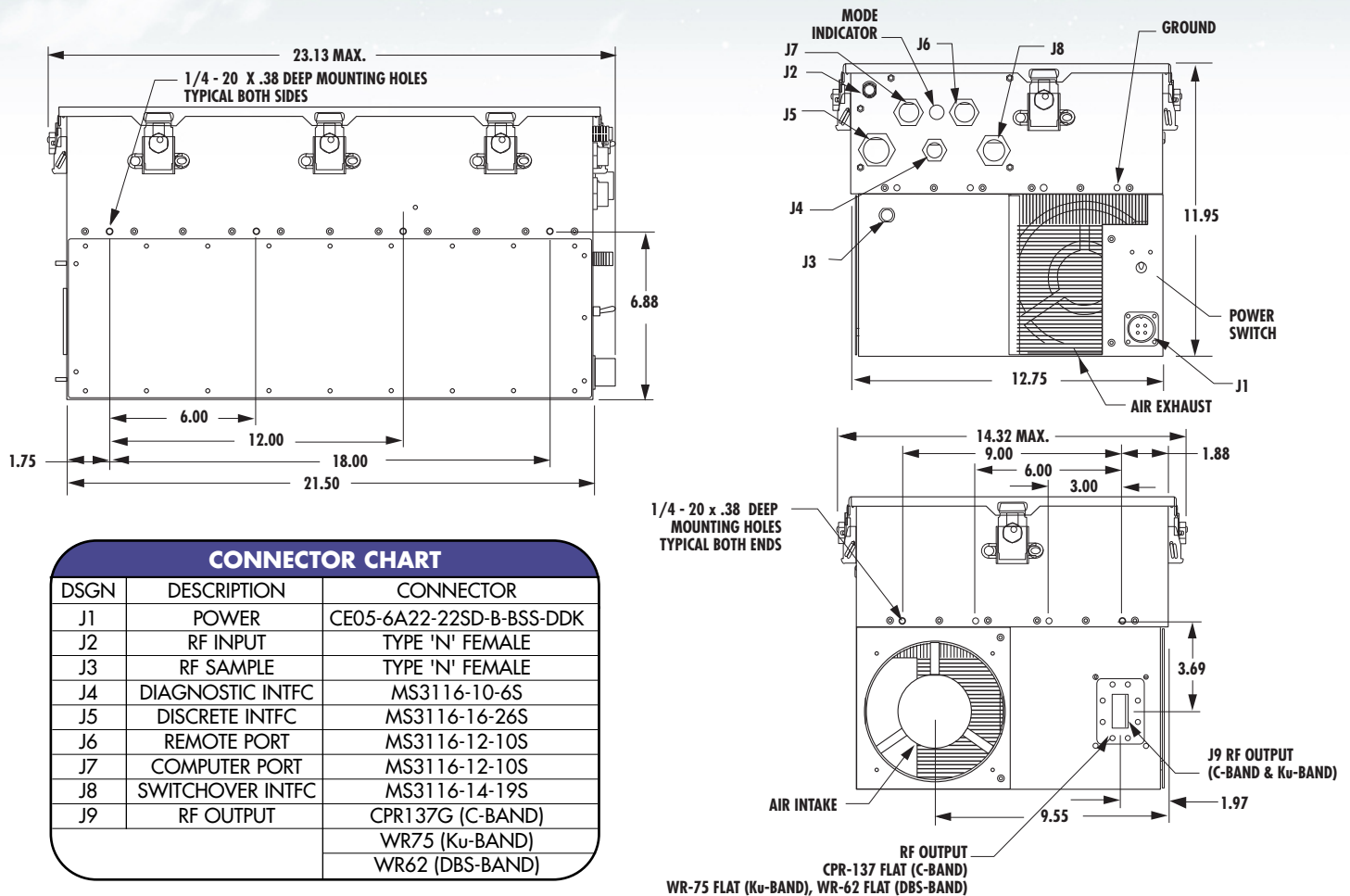

### ENVIRONMENTAL SPECIFICATIONS

#### Operating Temperature:

-40°C to +50°C (derated 1.9°C per 1,000 ft. above sea level)

#### Non-Operating Temperature:

-50°C to +70°C

#### Relative Humidity:

100%, condensing

#### Operating Altitude:

10,000 ft. above sea level (3,048 m)

#### Non-Operating Altitude:

50,000 ft. above sea level (15,240 m)

#### Vibration:

MIL-STD-810E, Method 514-4

#### Shock:

10g, 11ms half sine

### MECHANICAL SPECIFICATIONS

#### RF Connectors:

Input: Type N female  
Output: (Waveguide Flange)  
C-Band: CPR137G  
Ku-Band: WR75  
DBS-Band: WR62

#### Installed Weight:

79 lbs./36 kg typical

#### Cooling:

Forced air, 2.0" clearance required

#### Acoustic Noise:

<68 dBA max. at 1 meter

### PHYSICAL SPECIFICATIONS

#### Dimensions:

(not including connectors and hardware)

13.2" H (335 mm)

16.4" W (416 mm)

31.2" L (792 mm)

#### Air Flow:

250 CFM

MCL, INC  
501 S. Woodcreek Drive, Bolingbrook, IL U.S.A., 60440-4999 • 630-759-9500 FAX: 630-759-5018  
24-HOUR CUSTOMER SUPPORT NUMBER IN THE USA: 1-800-743-4625  
OUTSIDE THE USA: 312-461-4536 • www.mcl.com



MT4400-10.08