



# MT7100

TRAVELING WAVE TUBE  
HIGH POWER AMPLIFIER

THE RUGGED AND ECONOMICAL  
SOLUTION FOR UPLINK APPLICATIONS



C-BAND: 2250W  
X-BAND: 2250W  
2500W  
DUAL C/X-BAND: 1000W/2000W

## AVAILABLE SYSTEM OPTIONS:

MT7111 1 + 1 Redundant System

MT7112 1 + 2 Redundant System

MT71PC Phase Combined Redundant System

Other Configurations Available Upon Request

## AVAILABLE AMPLIFIER OPTIONS:

Manual Override

Internal Linearizer

Block Upconverter with External L-Band Input

Extended Frequency Band

Remote Panel

3-Phase Line Conditioner

## FEATURES:

**Modular Design**

**RoHS - 5 Compliant**

**Software Communications Configuration  
for Both Remote and Computer Interfaces**

**Continuous Attenuator Adjustment shown in dB**

**Extensive Control and Status Capabilities**

**State-of-the-Art High Efficiency Resonant  
Power Supply**

ISO 9001



501 S. Woodcreek Drive, Bolingbrook, IL U.S.A., 60440-4999 • 630-759-9500 FAX: 630-759-5018

# MT7100

## TRAVELING WAVE TUBE HIGH POWER AMPLIFIER

ELECTRICAL SPECIFICATIONS	C-BAND	X-BAND		DUAL	
	2250 W	2250 W	2500 W	C-BAND	X-BAND
Frequency Range (F <sub>0</sub> ):	5.850 - 6.425 GHz Option: 5.850 - 6.650 GHz Option: 5.850 - 6.725 GHz	7.9 - 8.4 GHz		5.850 - 6.425 GHz	7.9 - 8.4 GHz
Output Power (min.): Tube Output Flange:	2250 W (63.52 dBm)	2250 W (63.52 dBm)	2500 W (64.0 dBm)	1000 W (60.0 dBm)	2000 W (63.0 dBm)
HPA Rated Output:	2000 W (63.0 dBm)	2000 W (63.0 dBm)	2250 W (63.52 dBm)	900 W (59.5 dBm)	1800 W (62.6 dBm)
Gain:			75 dB		
At Rated Power (min.):			78 dB		
Small Signal Gain (SSG) (min.):			30 dB (0.10 Inc)		
Attenuation Range with optional SSA (min.):					
Maximum SSG Variation Over:					
Narrow Band:		1.0 dB/40 MHz		1.4 dB/40 MHz	
Full Band:	2.5 dB		2.0 dB		
Per 500 MHz:			2.0 dB		
Slope, Max.:			less than ±0.04 dB/MHz		
Gain Stability:			±0.25 dB/24 hr. max. (constant temperature)		
Stability, Any Freq. Over Entire Temp:			±1.0 dB typ.		
Input VSWR:		1.30:1 max.		1.30:1 max.	
Output VSWR:		1.20:1 max.		1.30:1 max.	
Load VSWR:		2.0:1 max. without damage, continuous			
AM/PM Conversion:					
At Rated Power:			7.0°/dB max.		
6 dB Below Rated Power:			2.5°/dB max.		
Residual AM Noise, Max.:					
To 10 kHz:			-50 dBc		
10 - 500 kHz:			-20 [1.5 + Log <sub>f</sub> (kHz)] dBc		
Above 500 kHz:			-85 dBc		
Harmonic Output, Max.:		-60 dBc		-10 dBc	-60 dBc
Noise & Spurious, Max.:					
Receive Band:	150 dBW/4 kHz, 3.7 - 4.2 GHz		-70 dBW/4 kHz, 7.25 - 7.75 GHz		
Transmit Band (F <sub>0</sub> ):			-70 dBW/4 kHz		
Phase Noise:			10 dB below IESS Phase Noise Profile		
AC Fundamental:			-50 dBc max.		
Sum of All Spurs:			-47 dBc max.		
Intermodulation (for 2 equal carriers relative to single carrier rated output):	Total P <sub>0</sub>		IM Product		
Extended C-Band Only	-4 dB		-16 dBc		
Typical Linearizer Option Performance:	-4 dB		-27 dBc		
Extended C-Band Only (Linearizer)	-4 dB		-25 dBc		
Group Delay:			Any 40 MHz Bandwidth		
Linear:			0.01 ns/MHz		
Parabolic:			0.005 ns/MHz <sup>2</sup>		
Ripple:			0.5 ns p-p		
Prime Power:					
Voltage:	120/208 VAC ±10%, 3-Phase, 47 - 63 Hz, Option 220/380 VAC ±10%, 3-Phase or 240/415 VAC ±10%, 3-Phase				
Power Consumption:	7.5 KVA typ., 8.5 KVA max.				
Power Factor:	0.95 min.				
In-Rush:	28A max.				
Input Transients:	EN61000-4-4, 4-5, 4-11 (Surge, Fast Transients, Line Dropout)				

Notes: Performance information is subject to change without notification. Contact MCL for the latest specifications (TN7100-1).

## RF BLOCK DIAGRAM

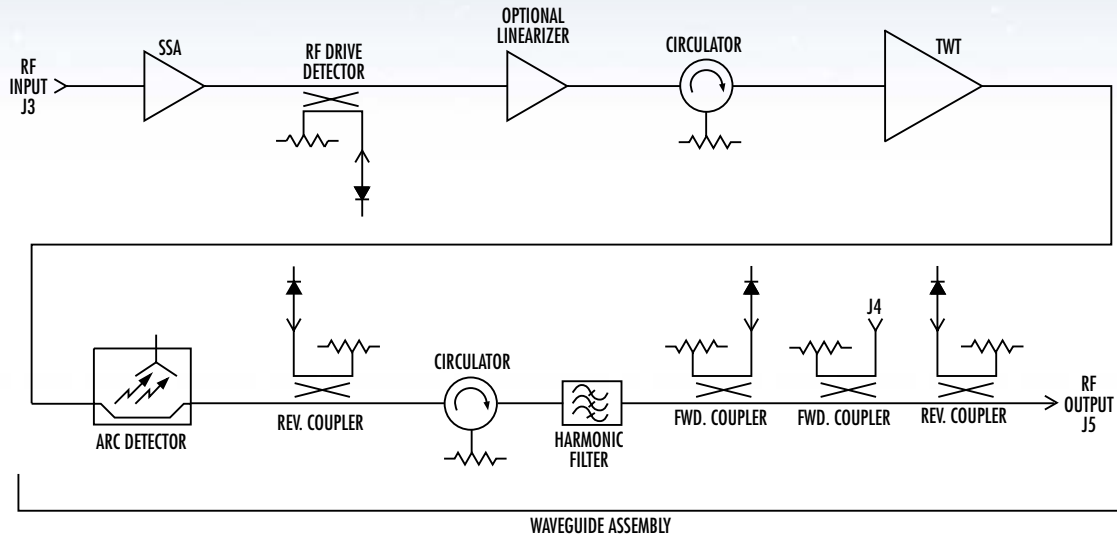

## CONTROL AND STATUS CAPABILITIES

TYPE	FUNCTION		
Controls	Power ON/OFF Auto Switching (1:1) RF ON/OFF Antenna Position (1:1) Units Select	Hold Power ON/OFF Transmit/Standby Fault Counter ON/OFF Attenuation Local/Remote/Computer	Filament ON/OFF Manual Switching (1:1) Reset Load Position (1:1)
Adjustable Parameters	Auto Power Comm Band Rate Comm Address Filament Under Current Fault RF Reflected Power Alarm	RF High Alarm RF Low Alarm RF Reflected Power Fault Tube Overdrive Alarm Linearizer Band Selection	Tube Temperature Alarm Tube Overdrive Fault Time and Date Comm Protocol RF High Fault
Displays (Remote and Computer Only)	RF Forward Power RF Reflected Power Tube Drive Power	Helix Current Filament Delay PS Temperature	Helix Voltage Filament Current Tube Temperature
Faults	Tube Temperature Switch Helix Surge Current User Interlock Chassis Interlock Isolator Reflected Power Fault Log	HV Over Voltage HV Under Voltage PS Temperature WG Arc (2) RF High Summary	Helix Run Current Arc Test Failed WG Pressure Filament Under Current Reflected Power Tube Overdrive
Alarms	RF High Tube Overdrive Summary	AC Low Line RF Low Tube Temperature	RF Reflected Power RF Switch Failed
Additional Status	Delay RF Low Switching ON/OFF Event Log Remote Tx +5 VDC	Transmit Selected Beam On ET Meter Com Rx +15 VDC RF Inhibit	Filament ET Meter Com Tx Sample Port Cal Table Remote Rx -15 VDC

# MT7100

## OUTLINE DRAWING

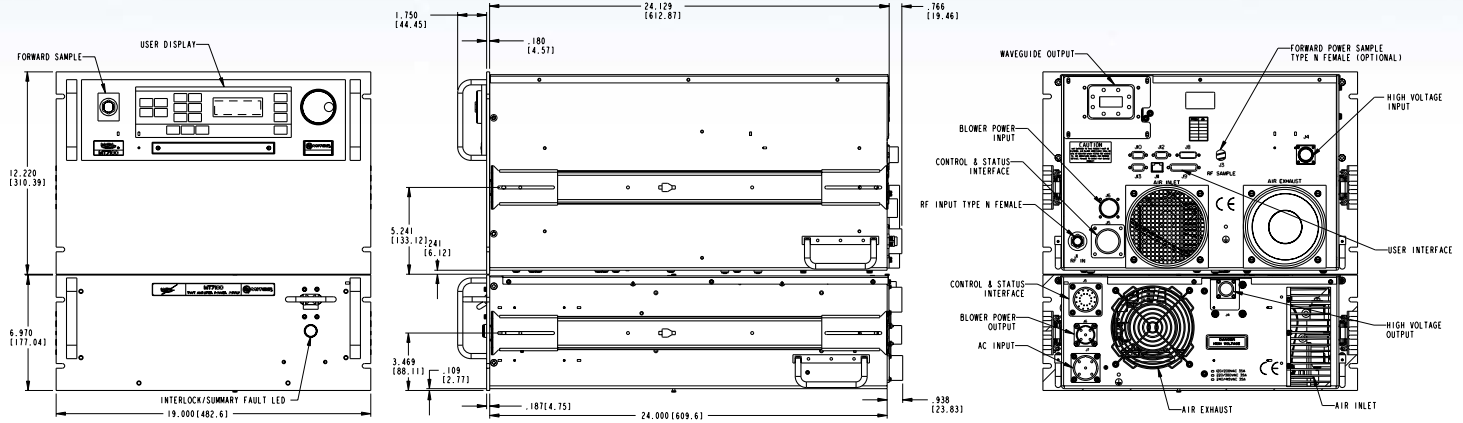

### ENVIRONMENTAL SPECIFICATIONS

**Operating Temperature:**

-10°C to +50°C

**Non-Operating Temperature:**

-40°C to +70°C

**Relative Humidity:**

95%, condensing

**Operating Altitude:**

10,000 ft. above sea level (3,048 m)  
with standard adiabatic derating

**Non-Operating Altitude:**

50,000 ft. above sea level (15,240 m)

**Vibration:**

MIL-STD-810E, Method 514.4

**Shock:**

10g, 11ms half sine

### MECHANICAL SPECIFICATIONS

**RF Connectors:**

Input: Type N, Female  
Output: (Waveguide Flange)  
C-Band: CPR137F  
X-Band: WR112F  
Dual-Band: CPR137F

**Installed Weight:**

Depending on Options  
204 lbs. nominal/93 kg

**Cooling:**

Conductive Forced Air

**Acoustic Noise:**

72 dBA max.

### PHYSICAL SPECIFICATIONS

**Dimensions:**

19.25" H (489 mm)  
19.00" W (483 mm)  
24.00" L (610 mm)

**Air Flow:**

RF Drawer 230 CFM  
PS Drawer 150 CFM

MCL, INC • 501 S. Woodcreek Drive, Bolingbrook, IL U.S.A., 60440-4999 • 630-759-9500 FAX: 630-759-5018  
24-HOUR CUSTOMER SUPPORT NUMBER IN THE USA: 1-800-743-4625  
OUTSIDE THE USA: 312-461-4536

MITEQ • 100 Davids Drive, Hauppauge, NY U.S.A., 11788 • 631-439-9220 FAX: 631-436-7430



MT7100-12.07